

• APTIV •

DESIGNED FOR THE FUTURE OF MOBILITY

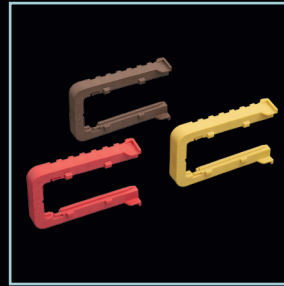
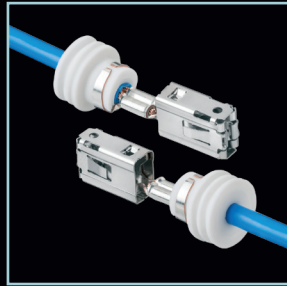
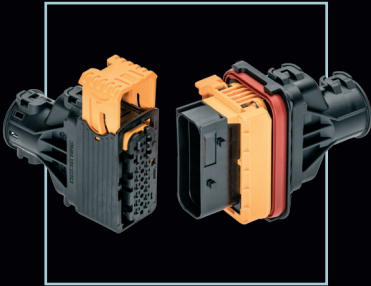

CTCS CONNECTION SYSTEM

Commercial vehicle and heavy duty portfolio



At Aptiv, we are born to move

Aptiv is a **global technology company** that develops safer, greener and more connected solutions enabling the future of mobility.

Headquartered in Dublin, Aptiv has more than 200,000 employees and operates 11 technical centers, as well as manufacturing sites and customer support centers in 48 countries.

VISIT [APTIV.COM](https://www.aptiv.com) →

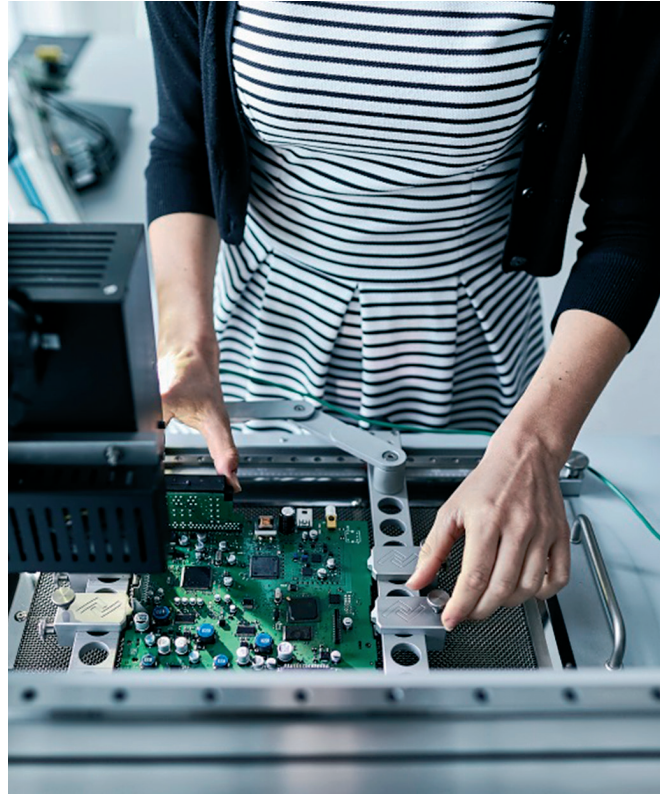

Major Design Centers Worldwide





The world of **transportation**

Aptiv has been a trusted automotive supplier for decades, introducing practical innovations in the areas of safety, efficiency, and connectivity. The transportation market has been advancing in these areas and Aptiv can offer product solutions designed for the tougher operational and environmental requirements.

Commercial and recreation vehicles are often exposed to higher levels of environmental forces, including vibration, dust, water, debris, and temperature. To protect the integrity of the electrical system, high performance connection systems are required.

To deliver superior performance, a number of complex factors in the electrical system must be addressed in the component design, including sealing, locking features, and materials.



A new generation of transportation fleets

As fleets and owner operators are looking to increase profitability and decrease negative footprint on the environment, vehicle manufacturers are considering alternative powertrains to meet new demands of their customers.

Alternative powertrain solutions now include more sophisticated ICE (Internal Combustion Engine), hybrid, battery electric, CNG (Compressed Natural Gas), and fuel cell technologies. And the infrastructure development is keeping up with the pace of vehicle technology advancements. The trend for a greener future is now becoming a reality across the world through truck, bus, and construction/agriculture fleet operations. And it has a potential to positively impact thousands of people through decreased pollution and improved air quality.

These alternative powertrains, however, increase the complexity of the electrical architecture, requiring higher reliability. The transportation market also has more stringent performance requirements as vehicles are exposed to higher operational temperature and extreme environmental forces. These two factors drive the demand for more robust connection systems designed specifically with the market's unique conditions in mind



A connection system designed for **the future**

The CTCS connector and CTS terminal families have been designed to meet the demanding requirements of commercial and heavy duty applications, specifically to address new emission regulations and enable the generation of environmentally-friendly vehicles.

The CTCS (Compact Transportation Connection System) family offers an integrated system solution to a wide variety of vehicle interconnections, ranging from unsealed cab to sealed on-engine applications, to options with flame-retardant material, to performance-boosting accessories. It was designed to meet or exceed a range of industry and customer validation standards and deliver improved performance over the competition.

This heavy duty connection system provides superior resistance against vibration and environmental forces, protecting the integrity of the electrical system from high operating temperatures, debris, and water. CTCS serves as a reliable backbone to all vehicle electronics, including powertrain, safety, entertainment, and telematics.

Robust features, meaningful benefits

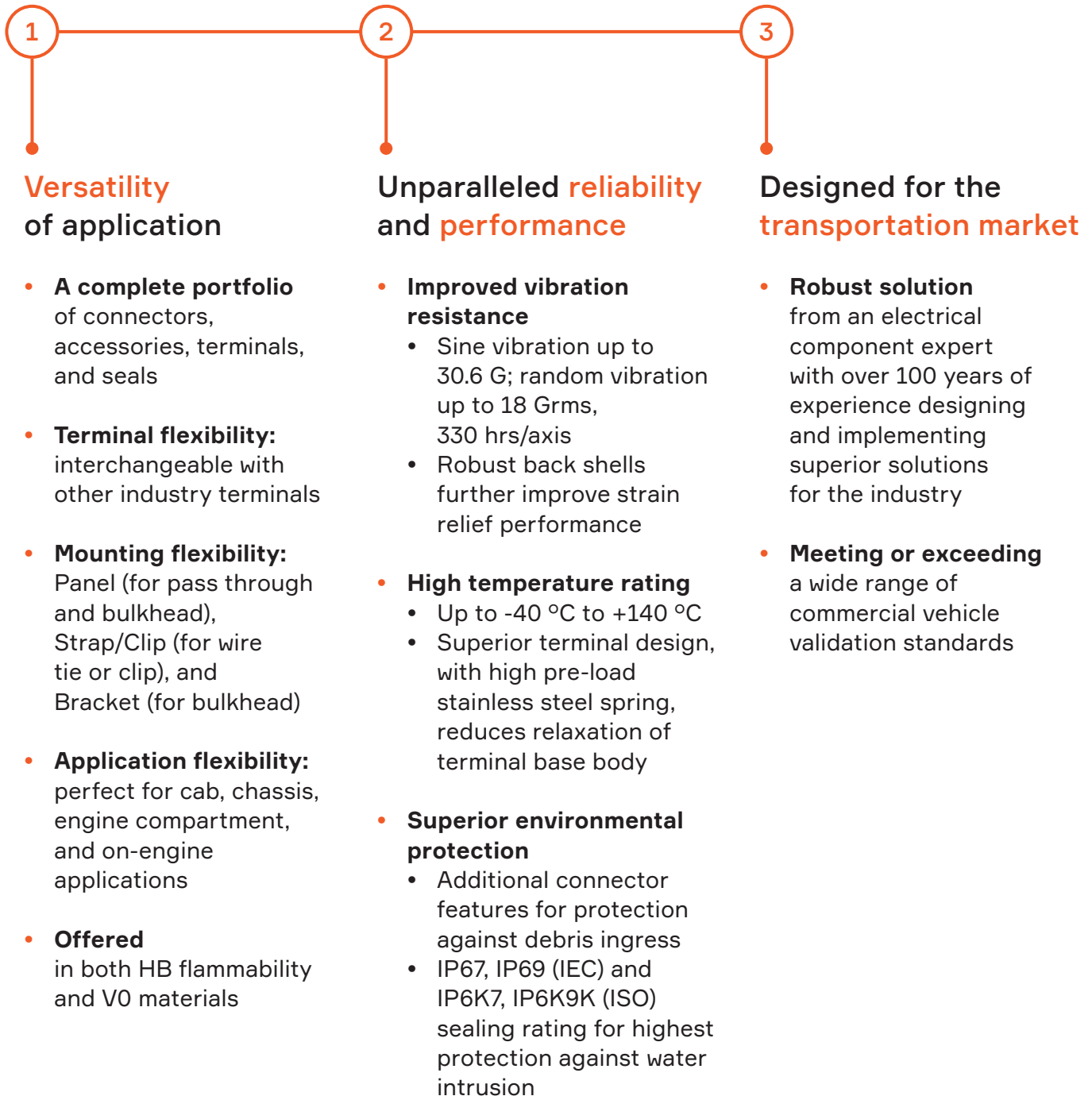

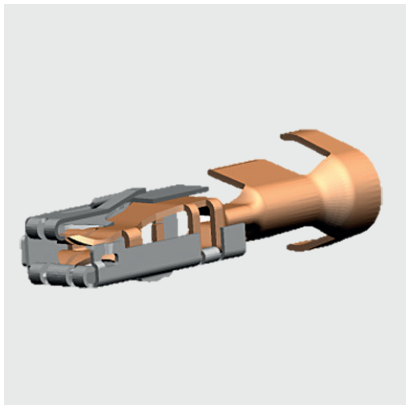

High pre-load stainless steel spring

Superior vibration and relaxation resistance



Additional structure on back shells

Designed for maximum mechanical robustness and mud and dust protection

- 1 Heavy ribbing
- 2 Strapping points fully integrated with cover for maximum retention of harness
- 3 Four shrouded locks

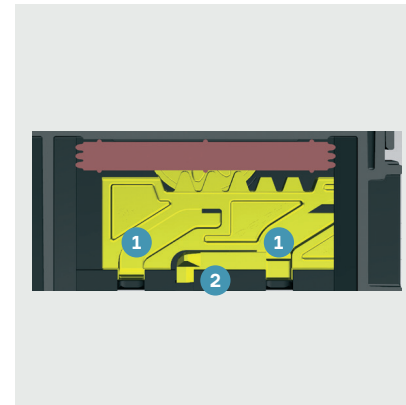

Pre-staged locking mechanism (SP and XP Series)

- 1 Pre-staging features in slider to aid in proper mating
- 2 Slider lock is firmly retained and only released upon installation onto mating connector

Mounting flexibility

Aptiv provides a range of mounting options for maximum application flexibility.



Strap/Clip Mount

- 1 Tie strap area
- 2 Clip slot

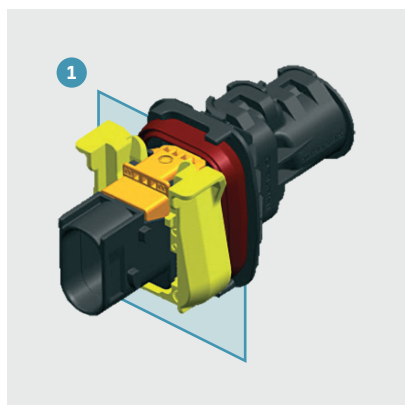

Panel Mount

- 1 1.0 - 3.5 mm wall thickness capability



Pass-through Bracket Mount

A wide family range

1

Connectors

CTCS connectors offer wide application versatility and a perfect match for your design needs.

CTCS connector range covers:

- Inline and device applications
- 2 through 62 way configurations
- 1.5, 2.8, 6.3 mm blade sizes, and mixed cavity configurations
- Sealed and unsealed applications
- Flame-retardant material option (V0)
- Panel, strap/clip, and bracket male mounting options
- Two different lock assist mechanisms for sealed connectors: Slider lock and Lever lock



2

Terminals

CTCS connectors are compatible with both Aptiv and other industry terminals. Aptiv's CTS tanged terminals offer premium vibration, temperature, and sealing performance.

Terminal range covers:

- 1.5, 2.8, and 6.3 mm blade sizes
- 0.08-6.0 mm² / 28-10 awg cable sizes
- Tin, silver, and gold plating options

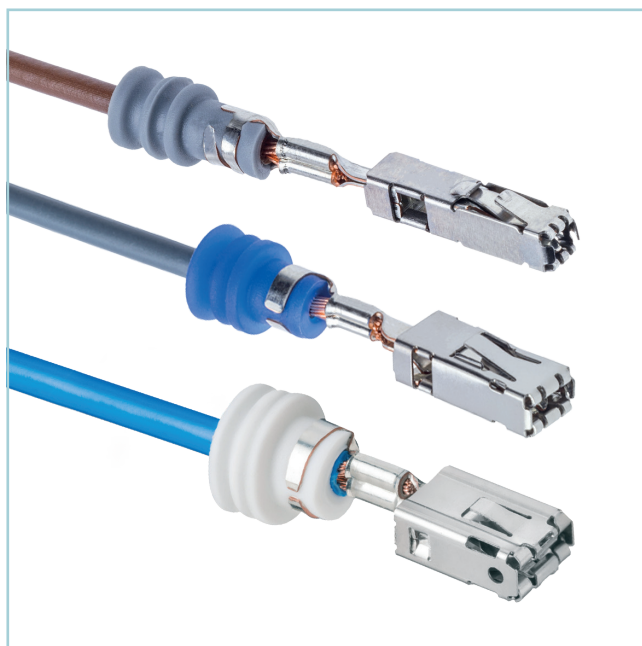

3

Seals

Both cable seal and cavity plug options are available, covering a wide range of cable gages and all CTCS cavity sizes.



4

Accessories

CTCS housings can be supplemented with optional accessories, which can further improve vibration performance and harness interconnection integrity. The following accessories, produced by an Aptiv brand HellermannTyton, are available:

- 180° or 90° back shells
- 1.0-3.5 mm² fixing slides
- Caps
- Clips and wire ties

For more information visit www.hellermanntyton.com

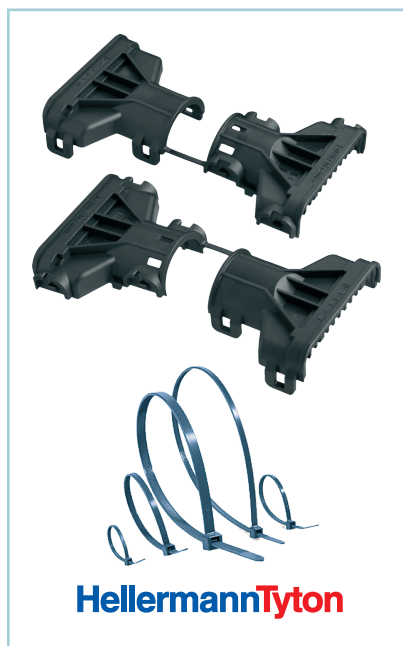

5

Hand crimp tools

Hand crimp tools are available for CTS female and male terminals. No solder required.



The right connection for the right job

PERFORMANCE	CTCS UNSEALED	CTCS SP	CTCS XP
Max vibration Sine (G) / Random (Grms)	n/a / 2.17	23.9 / 12.4	30.6 / 18
Max temperature (°C)	-40 to +85	-40 to +120	-40 to +140
Sealing IP (IEC / ISO)	5 / 5K	67, 69 / 6K7, 6K9K	67, 69 / 6K7, 6K9K
Flame resistance	HB flammability	HB flammability, V0	V0
Available cavity configurations	4, 18, 25, 36	15, 21, 26, 39, 62	2, 3, 4, 6, 7, 8, 10, 12, 15, 16, 18
Mounting options	None	Panel, Bracket	Panel, Strap/Clip
Lock assist type	Standard, Lever lock	Lever lock	Slider lock
Applications	●	● ● ●	● ● ●

- Cab
- Chassis
- On-engine
- Engine Compartment

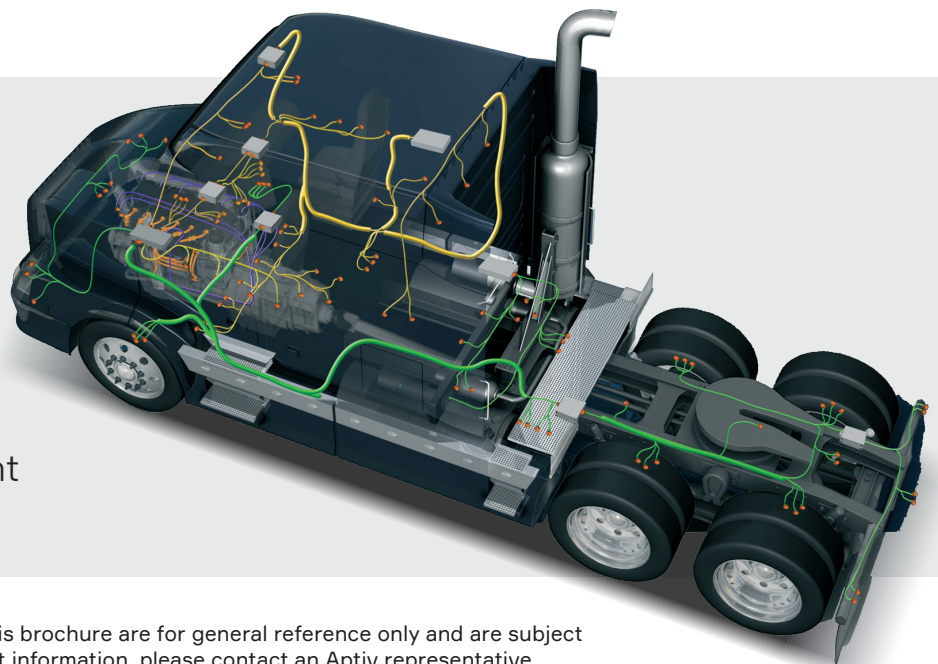

Specifications and performance data in this brochure are for general reference only and are subject to change without notice. To verify product information, please contact an Aptiv representative.

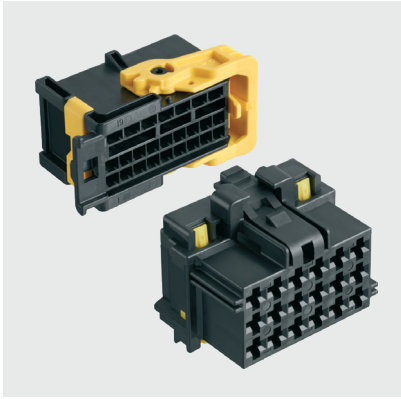

CTCS UNSEALED

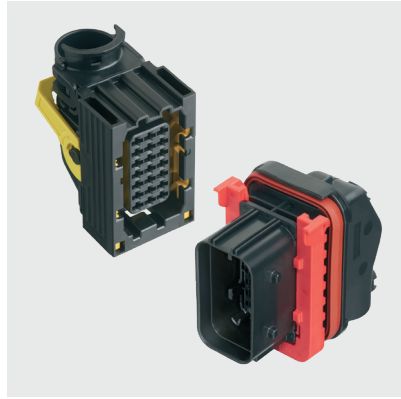

CTCS SP

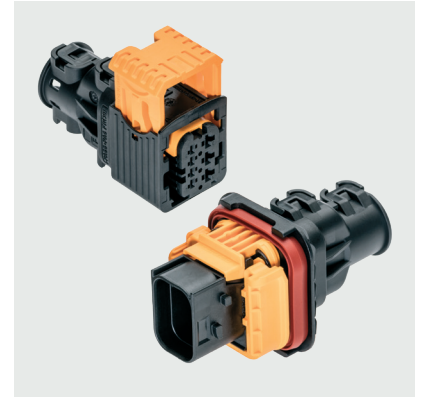

CTCS XP

Exploded view

- 1 Connector housing
- 2 Secondary lock
- 3 Lever lock
- 4 Seal
- 5 Fixing slide
- 6 Slide
- 7 Panel
- 8 Back shell
- 9 Cavity module
- 10 Male inner connector

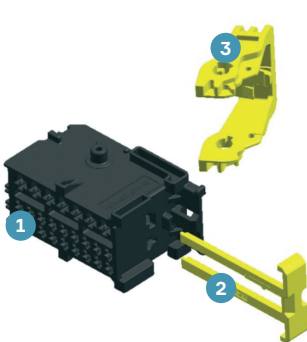

1.5/2.8 25W Female

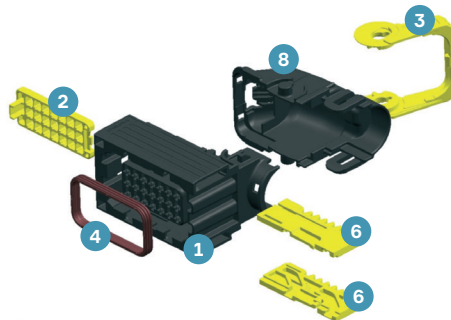

1.5/2.8 21W Female (HB*)

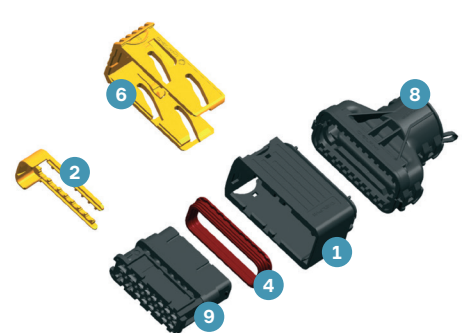

1.5/2.8 16W Female (V0)**

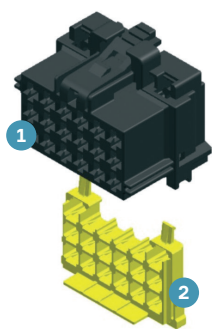

2.8 18W Female

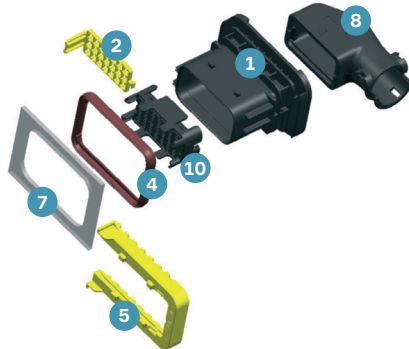

2.8 21W Male (HB*)

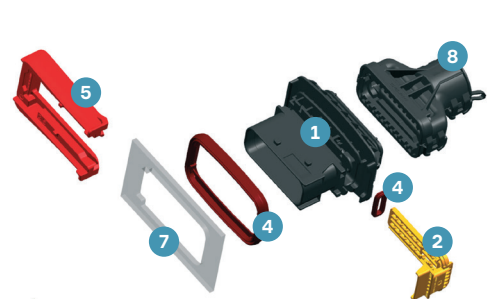

1.5/2.8 16W Male (V0)**

* HB option comes with yellow-coded locks and slides
 ** V0 option comes with orange-coded locks and slides

Available configurations

CONNECTORS						
# of ways	Performance series	Lock assist type	Gender	Male mounting type	Available terminal configurations	Applications
SEALED CONNECTORS						
2	XP	Slider lock	Female, Male	Panel & Strap/Clip	1.5, 2.8, 6.3	Inline & Device
3	XP	Slider lock	Female, Male	Panel & Strap/Clip	1.5	Inline & Device
4	XP	Slider lock	Female, Male	Panel & Strap/Clip	2.8	Inline & Device
6	XP	Slider lock	Female, Male	Panel & Strap/Clip	1.5	Inline & Device
7	XP	Slider lock	Female, Male	Panel & Strap/Clip	1.5/2.8	Inline & Device
8	XP	Slider lock	Female, Male	Panel & Strap/Clip	1.5, 2.8	Inline & Device
10	XP	Slider lock	Female, Male	Panel	1.5/2.8	Inline & Device
12	XP	Slider lock	Female, Male	Panel	1.5	Inline & Device
15	XP	Slider lock	Female, Male	Panel & Strap/Clip	1.5/2.8	Device
16	XP	Slider lock	Female, Male	Panel & Strap/Clip	1.5/2.8	Inline & Device
18	XP	Slider lock	Female, Male	Panel & Strap/Clip	1.5	Inline & Device
15	SP	Lever lock	Female	-	2.8	Inline & Device
21	SP	Lever lock	Female, Male	Panel	2.8	Inline & Device
26	SP	Lever lock	Female, Male	Panel	1.5/2.8/6.3	Inline & Device
39	SP	Lever lock	Female, Male	Panel & Bracket	2.8	Inline & Device
62	SP	Lever lock	Female, Male	Panel & Bracket	1.5/2.8	Inline & Device
UNSEALED CONNECTORS						
4	Unsealed	Standard	Female	-	6.3	Device
18	Unsealed	Standard	Female	-	2.8	Device
25	Unsealed	Lever lock	Female	-	1.5/2.8	Device
36	Unsealed	Lever lock	Female	-	1.5	Device

Specifications and performance data in this brochure are for general reference only and are subject to change without notice. To verify product information, please contact an Aptiv representative.

TERMINALS

Blade size (mm)	Gender	Sealing	Base material	Plating options	Cable range (mm ²)	SAE gage (AWG)
1.5	F	Sealed & Unsealed	CuFe, CuNiSi	Sn, Ag, Au	0.08 - 1.5	28 - 16
1.5	M	Sealed & Unsealed	CuFe	Sn, Ag, Au	0.08 - 1.5	28 - 16
2.8	F	Sealed & Unsealed	CuNiSi	Sn, Ag	0.08 - 5.0	28 - 10
2.8	M	Sealed & Unsealed	CuFe	Sn, Ag	0.22 - 2.5	24 - 14
6.3	F	Sealed & Unsealed	CuFe	Sn, Ag	0.35 - 6.0	22 - 10

ACCESSORIES

Accessory type	Conduit diameter (mm)	Wall thickness (mm)	Available angles
Back shell	7.5 - 17	-	90° & 180°
Fixing slide	-	1.0 - 3.5	-
Cap	-	-	-

HAND CRIMP TOOLS

Terminal	Cable range (mm ²)	SAE gage (AWG)	Insulation type
CTS 1.5	0.35 - 2.0	24-14	PVC or XLPE
CTS 2.8	0.50 - 3.0	22-12	PVC or XLPE
CTS 6.3	0.75 - 3.0	20-12	PVC or XLPE

SEALS

Seal type	Blade size (mm)	Outside diameter (mm)	Material	Color
Cable seal	1.5	1.2 - 2.1	LSR	Red, gray, yellow
Cable seal	2.8	1.2 - 3.0	LSR	Blue, white, green
Cable seal	6.3	1.2 - 5.3	LSR	Yellow, white, red-brown, green, gray
Plug	1.5	-	LSR	White
Plug	2.8	-	LSR	Red-brown, white, green
Plug	6.3	-	LSR	Green



A

D

For more information

Download

VISIT [APTIV.COM](https://www.aptiv.com)



For more information:

Visit our website: aptiv.com

Browse our E-catalog: aptiv.com/en/solutions/connection-systems

CS-SP9-CTCS-En0124